



Smart Grid Communications Solutions

# HVBPL Communications over Transmission Lines

EEI TD&M Conference  
Denver, Colorado  
October 5, 2010

**Presented By:**  
**Bruce Renz, President, Renz Consulting LLC**  
**Nachum Sadan, CEO, Amperion, Inc.**

# Introducing HVBPL

- What is HVBPL?
  - High Voltage Broadband over Powerline is a patent -protected disruptive technology that delivers Megabit/sec data rates ,with only milliseconds of latency, over HV transmission lines
  - Developed exclusively by Amperion and tested on AEP lines
- The benefits of HVBPL
  - ***Reducing the cost of high speed station communications***
    - *No cost for using existing utility wires*
  - ***Enabling faster deployment of smart grid applications***
    - *Installs in a day compared to other methods that take much longer*
    - *70% of US transmission substations and 100% of distribution substations can be connected without having to wait for fiber*
- Technical challenges
  - The power grid is a harsh environment for broadband communications
  - Maintaining high availability of the communications signal in the presence of line noise requires sophisticated signal processing

# HVBPL Communications

- HVBPL can enable key applications
  - Replacing old pilot wire (PW) for protective relay applications
    - **Motivation:** significant cost savings; PW technology is being phased out
  - Transmission line digital protective relaying and control (interoperable with GE, SEL, others)
    - **Motivation:** accelerate deployment of advanced digital relays where there is no fiber
  - SCADA expansion to remote stations
    - **Motivation:** economical way to extend control and visibility to remote stations
  - Station surveillance
    - **Motivation:** protect critical assets (e.g. copper theft) and comply with DHS requirement
  - Utility wideband data applications
    - **Motivation:** employing such new digital technologies as WAMS, synchrophasors, smart grid communications, corporate data transfer
  - Transmission line and station equipment health
    - **Motivation:** enhance reliability of transmission assets

# HVBPL Development Timeline

- **2006 – 2007 Proof of Concept over 46 KV in Charleston WVA**
- **2007 – 2008 DOE funded RD&D project in Newark Ohio with AEP (EISA demonstration projects)**
  - Phase 1: 5.1 mile 69kV circuit connecting 3 stations with repeating; required developing an HV pole mounted intermediate BPL node
- **2009 – 2010 Amperion and AEP self-funded R&D**
  - Phase 2: 5.1 mile 69kV circuit connecting 3 stations without T-line repeating; Longest point to point link established between two stations 4.4 miles apart (world record BPL link length)
- **2010**
  - Phase 3: Lab tests of line applications; start field test on 69kV lines
  - Phase 4: 138kV technology development; lab test of 138kV couplers; start field installation in Q4
- **2011 Plans – Commercial deployments**
  - Typical configurations of 69kV stations that are 3 to 5 miles apart
  - Completion of 138kV field test, including applications

# 2006-2007 Charleston WVA 46kV HVBPL Demo

## Transmission BPL Proof of Concept Demo

November, 2006 – Charleston W VA

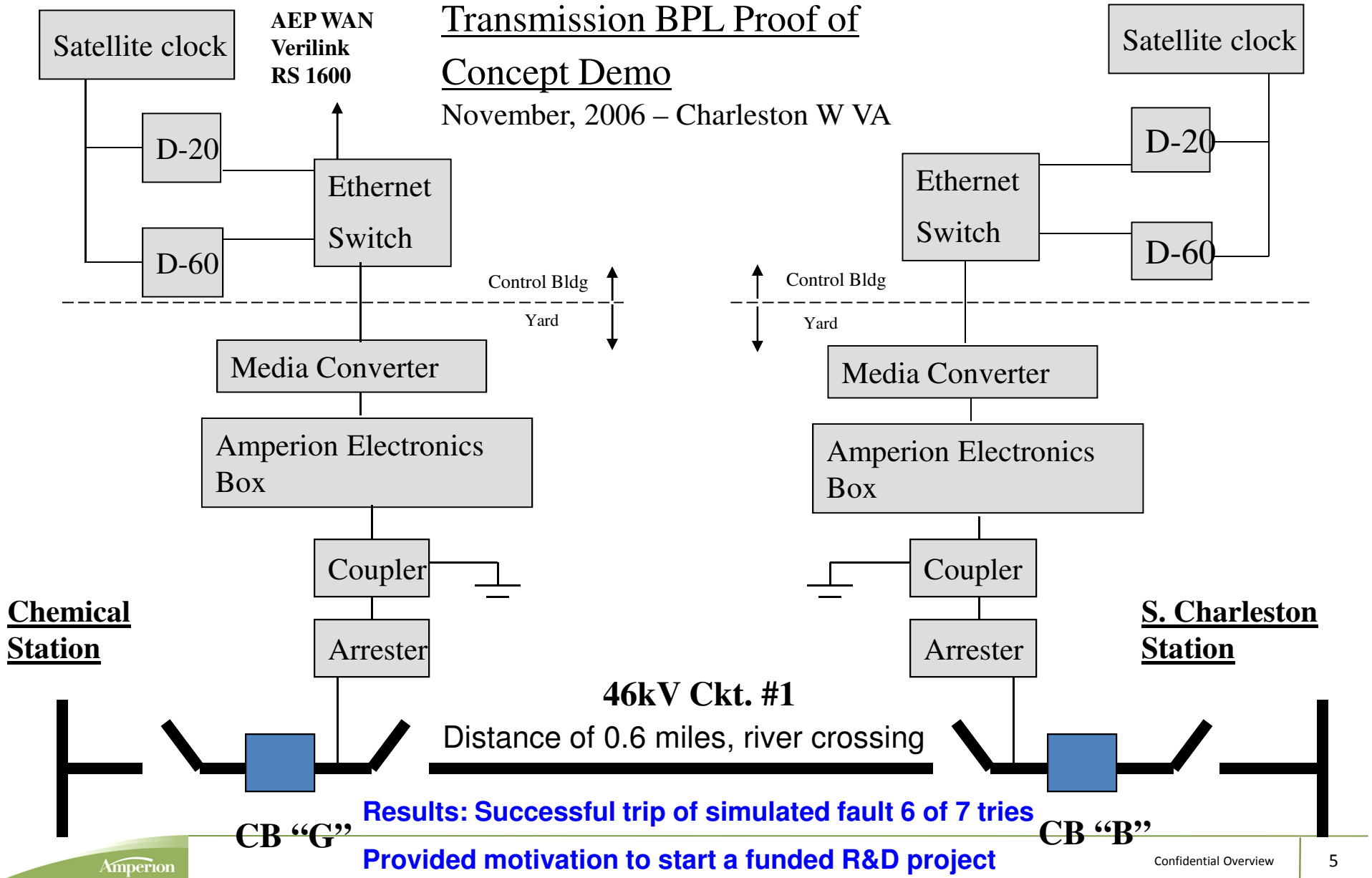

# 2007-2008 Newark OH 5.13 Mile 69kV Network

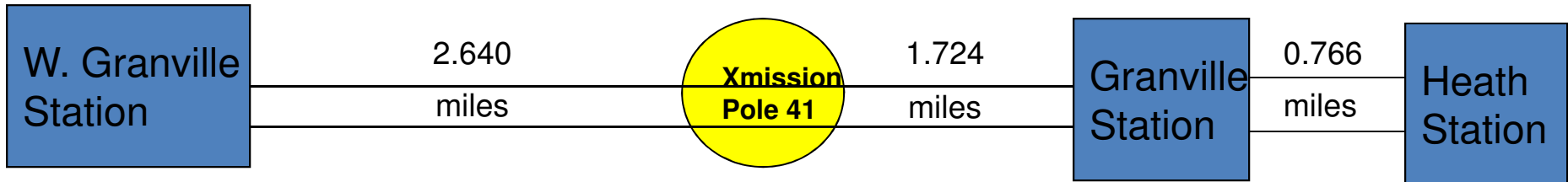

**Phase 1:** Used a line repeater on Pole 41 until April 2009

Further development has since eliminated the need for Pole 41 repeater at this installation (but line repeater application is still valid for longer runs)

**Phase 2:** Point to point links between stations without repeating

World's first – a 4.4 mile HVBPL link between Granville and West Granville

# Views From Spectrum Analyzers in Two Stations

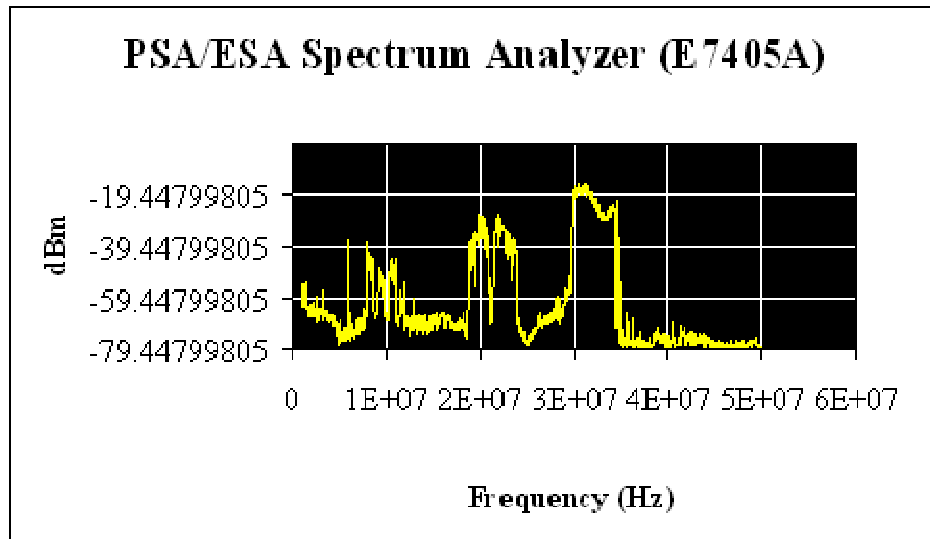

West Granville shows all 3 BPL links

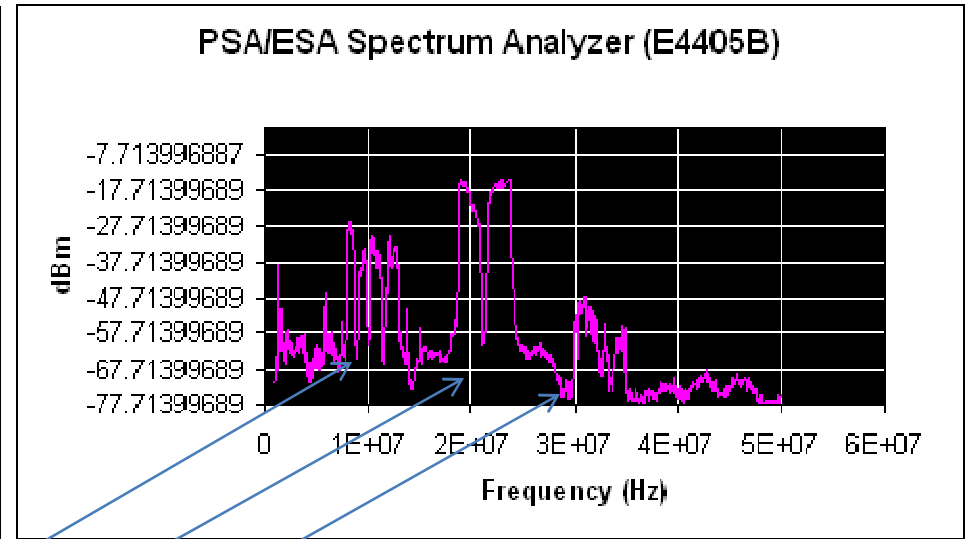

Heath shows all 3 BPL links

BPL Links use 5Mhz bands:

Channel 2: 8 to 13Mhz

Channel 4: 18 to 23Mhz

Channel 6: 29 to 34Mhz

**Measured Latency is 10 milliseconds end to end**

**Measured Throughput is 4-7Mbit/sec (9 to 15Mbps PHY)**

**High system availability – no loss of link communications**

# Transmission Powerline Coupling

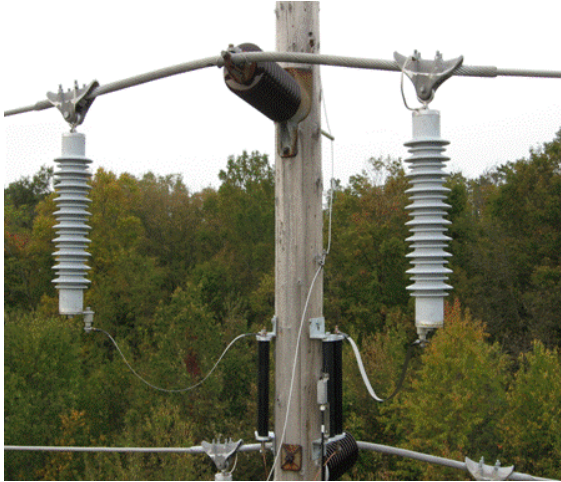

69kV HV T-Line Class Coupler



69kV HV Station Class Coupler

- **Safe and Reliable**
  - Uses standard utility arresters plus Amperion coupling components
- **Efficient**
  - Simple and quick to install
  - No special training required
- **Scalable**
  - From 46kV to 138kV
- **Cost Effective**
  - Lightning protection
  - Low maintenance costs
- **Single ended or Differential coupling**
  - Redundancy and channel backup
  - Link aggregation
  - Noise cancellation
- **Patent protected**

# HVBPL System Components



## Phoenix SG-5000

Two 200Mbps HVBPL modems

Intelligent switch:

- 6 10/100 Mbps FE ports

- 2 1000 Mbps GE ports (Fiber)

CPU with Amperion embedded SW

DC powered from station battery

Coax cable assembly  
Inside the switchyard



## HVBPL Coupler

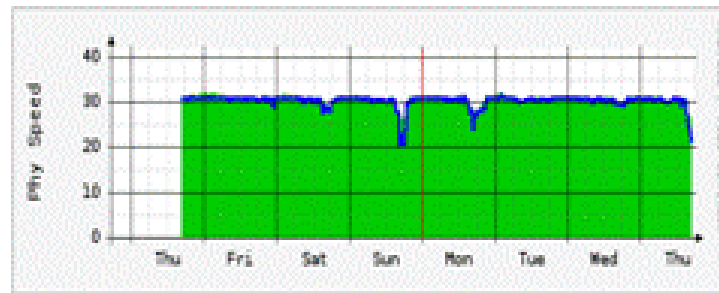

## Amperion NMS

Continuously monitors HVBPL modems and links health  
Performance graphs: system up time, throughput, latency

Historical reports: daily, weekly, monthly, yearly

Automatic alerts by email are optional

# 2010 HVBPL Project Plan

- **Phase 3:** Demonstrate that 69kV HVBPL will support all of the following applications:
  - Digital line protection
  - Digital station to station SCADA
  - Remote video surveillance of station integrity
  - Synchrophasor (PMU) data streaming
- Test 69kV commercial candidate system prior to deployment
- **Phase 4:** Demonstrate that HVBPL can be extended to 138kV and 10 miles
  - Part A: connecting East Broad to Taylor – 3.7 miles
  - Part B: Connecting East Broad to Kirk via Taylor – 10.36 miles
- Project participants
  - **AEP** – host utility
  - **Amperion** – communications supplier
  - **ABB, Cooper** – arrester suppliers
  - **SEL, GE** – relay and synchrophasor supplier
  - **Ametek, RAD** – multiplexer and converter suppliers

# HVBPL Fault Simulation Testing in AEP's Lab

Setup with Ametek BB Focus or RAD TDM/ETH converters

1. Established a baseline with back to back relay tests over serial cable
2. Added serial TDM to Ethernet converters and tested over straight Ethernet cable
3. Replaced Ethernet cable with HVBPL network and repeated test

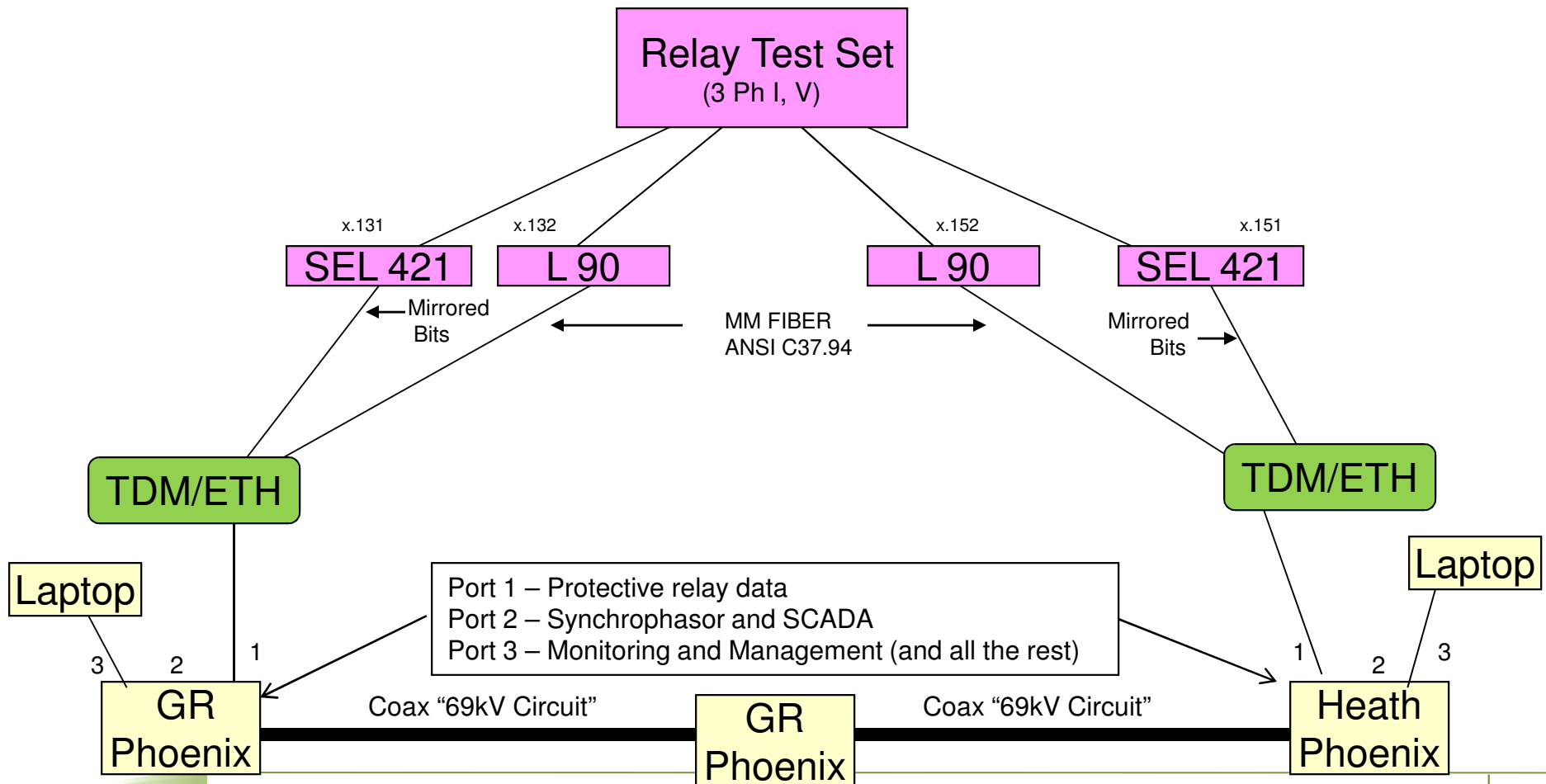

# AEP Lab Test Results

L-90 to L-90	L90+BB Focus	Over HVBPL One hop min	Over HVBPL One hop max	Over HVBPL Two hops min	Over HVBPL Two hops max	
20.68	24.91	31.25	38.39	40.08	46.19	6-7 msec spread min-max range
421 to 421	421+BB Focus	Over HVBPL One hop min	Over HVBPL One hop max	Over HVBPL Two hops min	Over HVBPL Two hops max	
27.98	32.79	40.80	44.88	48.06	53.28	4-5 msec spread min-max range

- All results are trip times in milliseconds
- Test results provided basis to proceed with field testing

# 69kV HVBPL Field Demo Test Setup

Test setup: Compare path A (Fiber) to path B (HVBPL)

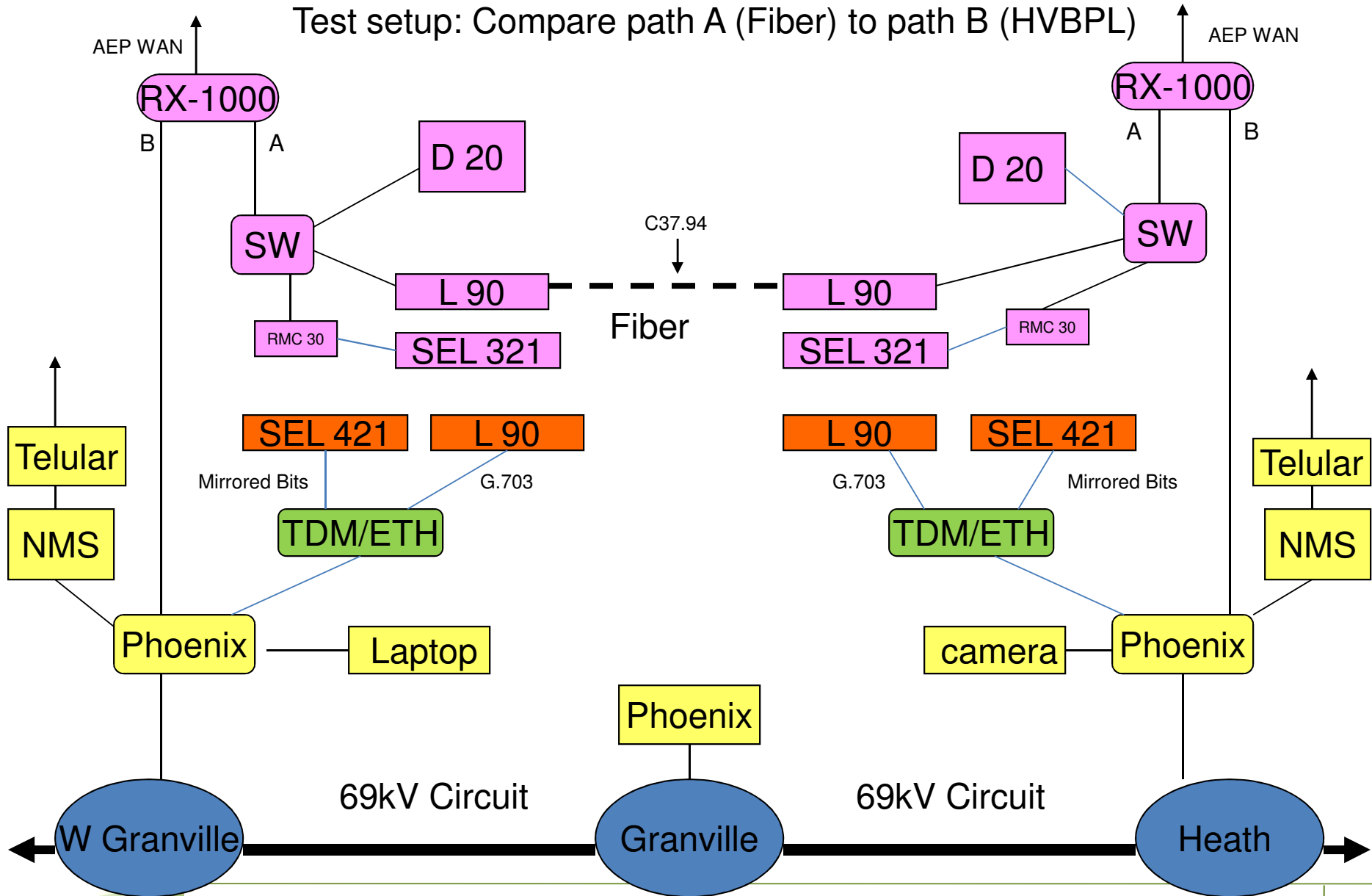

# Current Differential Relaying Test



69kV HVBPL Field Demo Test Setup

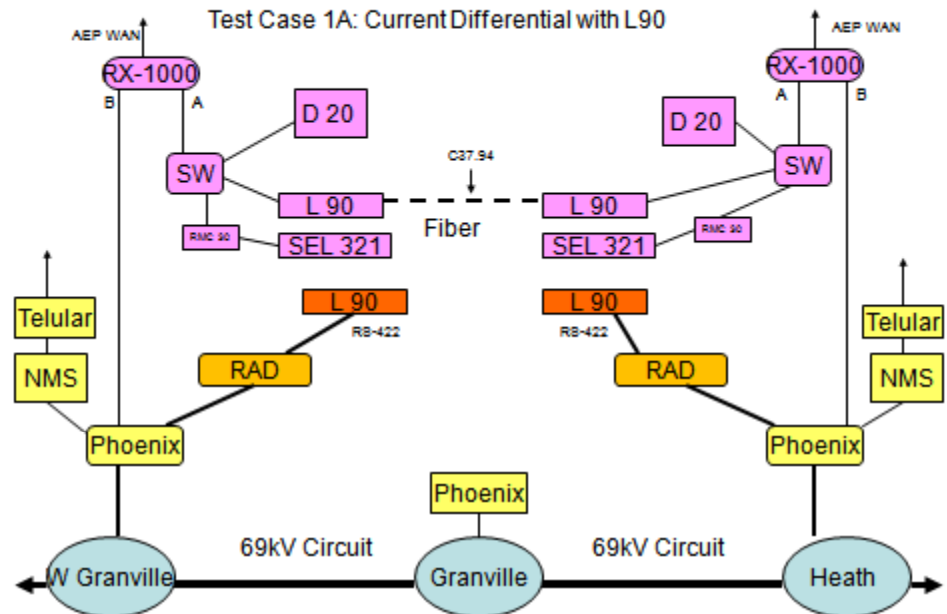

# HVBPL Relaying Test results

- Relay trip time for fault at 50% of line
  - Eight tests: results range from 38 to 42 milliseconds
- Similar results for faults at 5% and 95 % of line
- No trip for external faults
- Results similar to tests in lab
- About 20 milliseconds slower than a point to point fiber channel
  - Future enhancements in configuration settings and tighter integration will improve speed by 5 to 10 milliseconds

# Field Test Phase Fault L90 over HVBPL

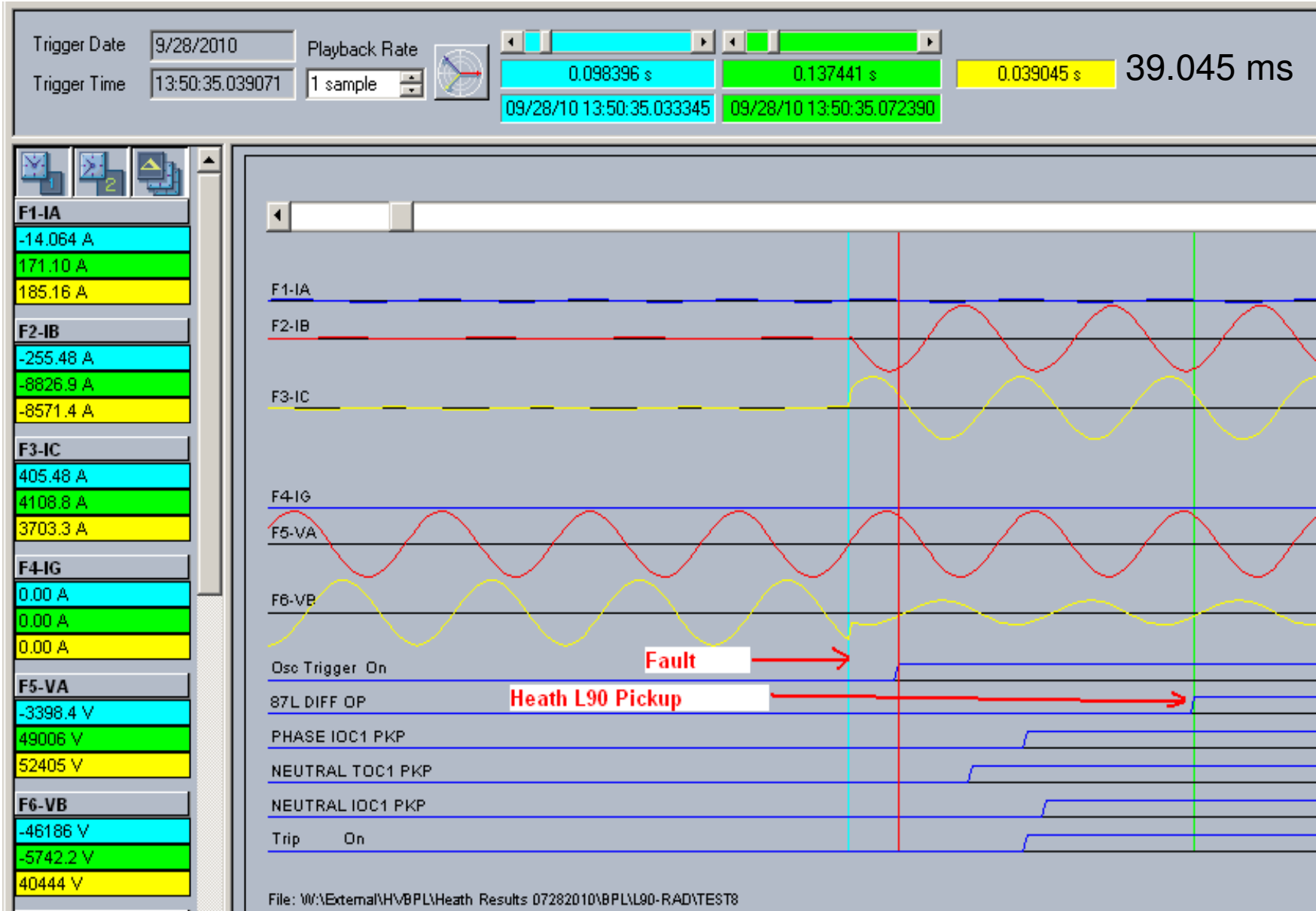

# HVBPL Project Summary

- Continuous operation achieved for many months over a 5-plus mile link using one station-based repeater
- Arrester coupling techniques proven successful and scalable
- FCC compliance demonstrated
- No equipment failures (several severe lightning and ice storms were experienced between 2007-2010)
- Successful arcing fault simulations in field
- Successful demonstration of line applications
  - Current differential and POTT protection (lab and field)
  - Video surveillance (lab and field)
  - SCADA and synchrophasor (lab)
- Development of 138kV coupling products
- Next Steps:
  - Run more applications on live wires
  - Complete line testing and get ready for commercial deployments
  - Transition 69kV product from R&D to production
  - Develop 138kV product set
  - Seek additional utility participation

# HVBPL Benefits

- Cost effective alternative to fiber - No cost of using own wires
- Takes much less time to install compared to alternatives
- Runs on utility's own wires providing full control and privacy of the network without cost to an outside service provider
- Supports real time response, low latency, and high bandwidth, meeting communications requirements of all smart grid applications
- Based on an Ethernet IP standard and is cyber secure
- Physical tapping near impossible due to HV medium
- Couplers provide lightning protection at no additional cost
- Enables deployment of modern line protection schemes in locations where there is no fiber or to backup existing fiber
- Potential to greatly accelerate the Smart Grid

# Q&A



Smart Grid Communications Solutions

Thank You!